

CBS Maxi-Cast

CBS Maxi-CastTM

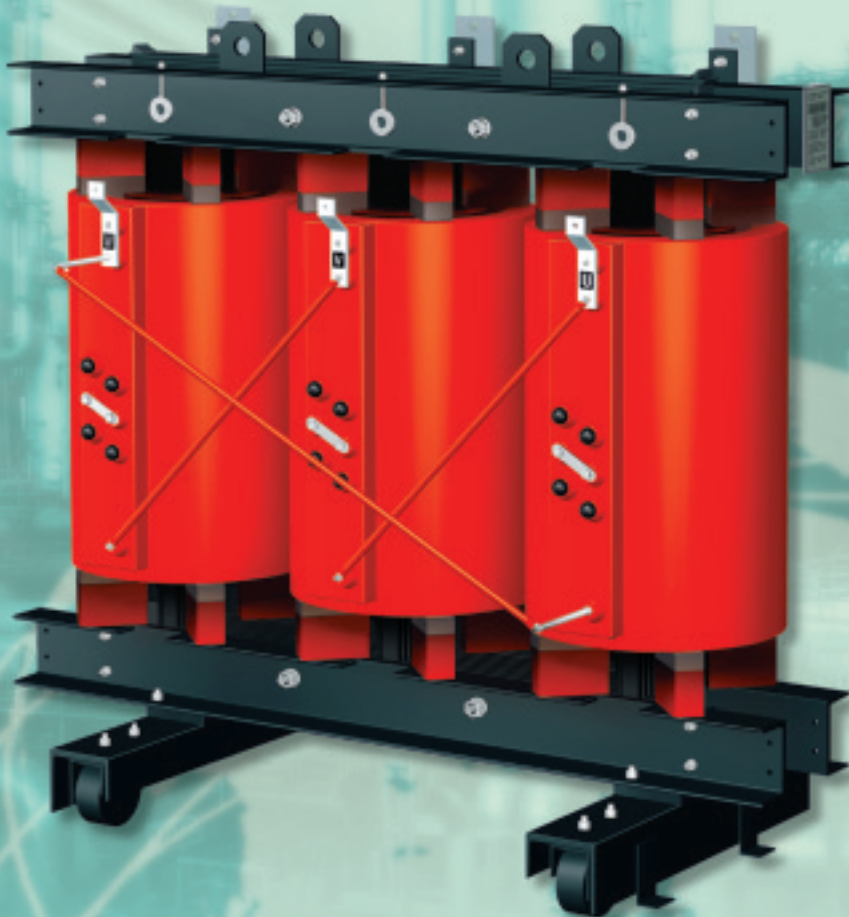

MAXI-CAST RESIN TRANSFORMERS



A GROUP CBS COMPANY

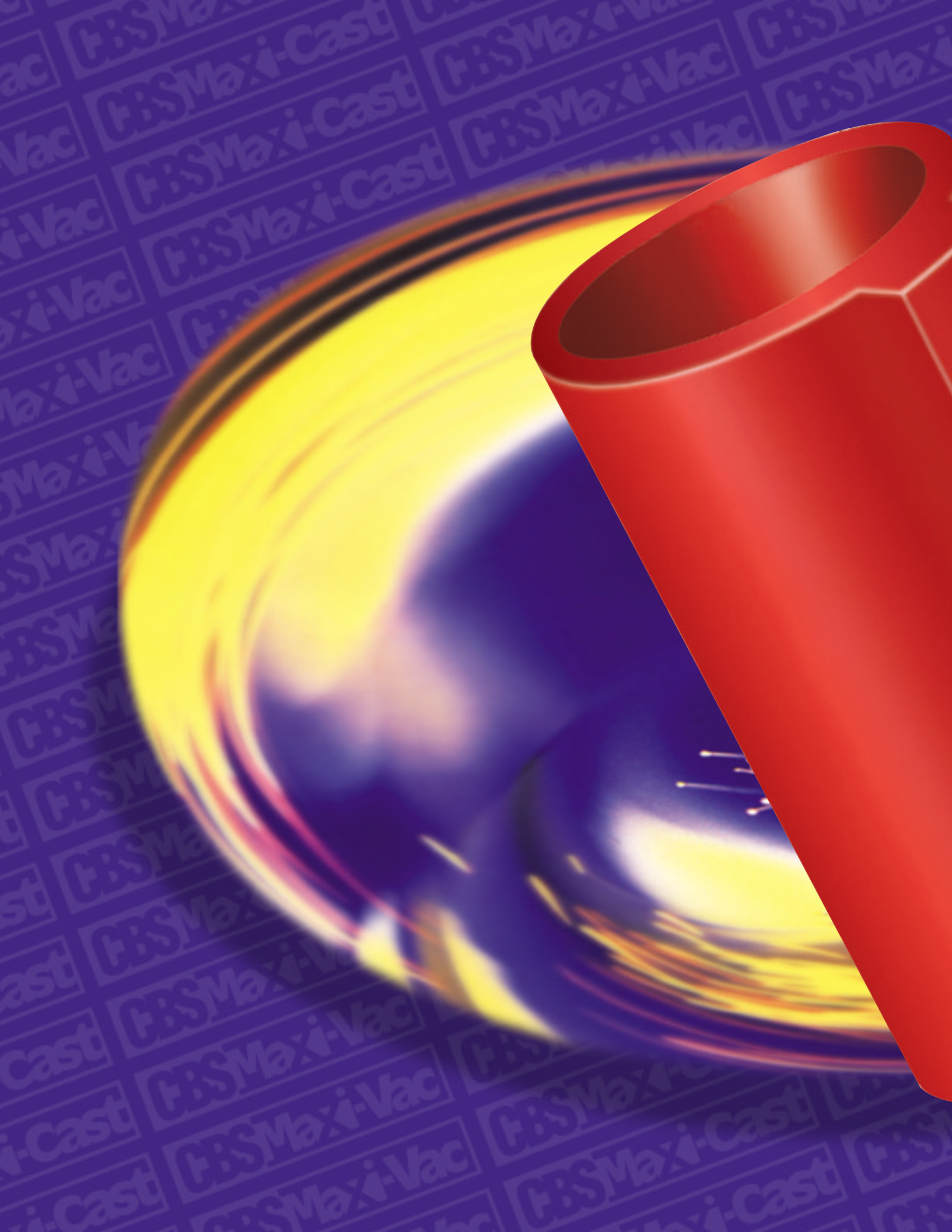

*Many models and sizes
available from stock for
same day shipment!*



CONTENTS

Introduction4
Application.....4
MAXI-CAST Transformer View.....5
Features6-7
Section View.....8
Construction9-11
Quality Assurance11
Technical Data12-13
Specifications14

INTRODUCTION

Great progress has been made in the development and improvement of transformers over the last decade.

The use of high quality insulation and the suitable selection of the coil structure design for high stress applications has advanced the design of the cast resin transformer.

The **MAXI-CAST** transformer combines the advantages of liquid-filled and dry type transformers. Cast resin transformers are fabricated with an epoxy resin which has a special low viscosity formula mixed under a vacuum. The copper windings are completely embedded between layers of glass fiber and impregnated in a special process with pure resin mixed under vacuum conditions. This unique casting method makes it possible to assure void-free epoxy penetration of both the inner layer and turn-to-turn insulation.

After casting, the coils are cured in a temperature time sequence which is controlled by a microprocessor to guarantee full and stress-free adhesion of the resin to the conductors.

It also provides a total safeguard against cracks under all circumstances. This result of the high technology application provides many unsurpassed characteristics.

FEATURES/CHARACTERISTICS

- Moisture proof
- No partial discharge
- High overload capability
- Superior Impulse voltage strength
- Short-circuit damage resistance
- Thermal shock resistance
- Superior fire resistant design
- Maintenance free
- Environmentally safe
- Very low noise
- Very low operating cost

APPLICATIONS

MAXI-CAST transformers can be used in various fields. Here are just a few possible applications:

- Indoor or outdoor unit substations
- Industrial and petrochemical plants
- Offshore platforms
- Harmonic applications
- Extremely corrosive and dirty applications
- Low noise applications
- Water supplies
- Transit systems
- SCR power supplies
- Grid, ring or radial networks
- Station auxiliaries
- Pad mount applications

MAXI-CAST TRANSFORMER

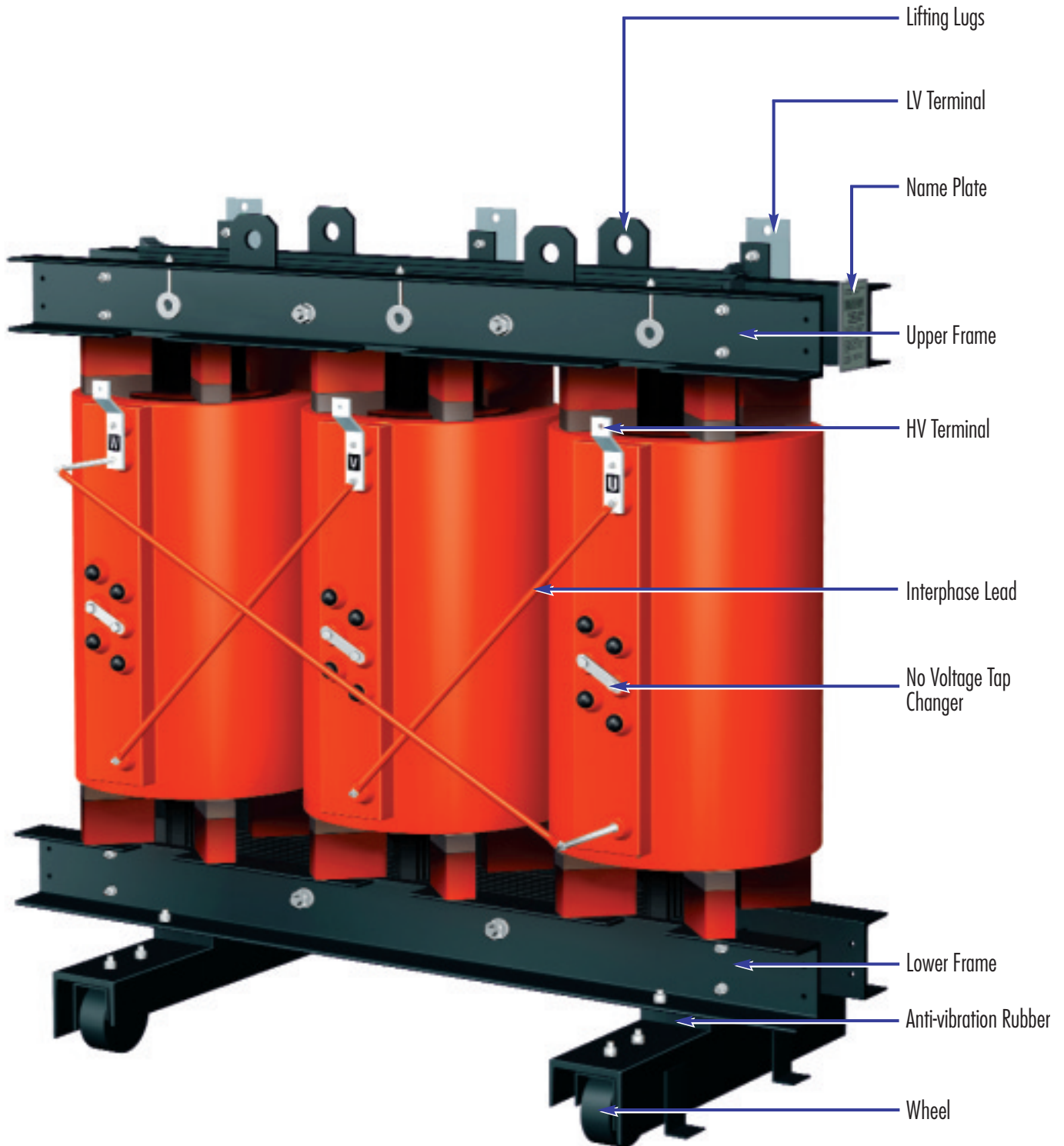

FEATURES/CHARACTERISTICS

MOISTURE PROOF

The complete casting of HV and LV coils under vacuum prevents the penetration of moisture into the winding and the breakdown by ionization. Therefore, it is suitable for both storage and operation in adverse environments, including prolonged storage in up to 100% humidity and is capable of being energized immediately after such storage without drying.

NO PARTIAL DISCHARGE

There is no possibility of partial discharge in **MAXI-CAST** transformers.

Each high voltage coil is individually tested for partial discharge before assembly to ensure a partial discharge-free operation under all circumstances, and to guarantee the life expectancy of the insulation system.

MAXI-CAST transformers are free of partial discharge at least up to 1.2 times of the rated voltage, and no visible corona at 2 times the rated voltage.

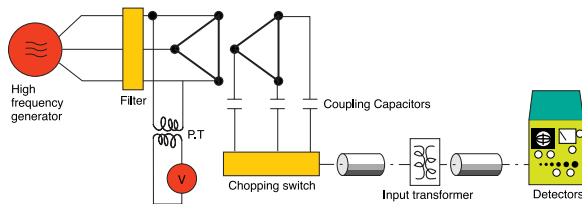

(CORONA TEST CIRCUIT)

HIGH OVERLOAD CAPABILITY

Based on the high thermal time constant factor of the windings, **MAXI-CAST** transformers can be overloaded for considerably longer periods of time than liquid immersed or dry type transformers. It has a greater capability to withstand sudden momentary high overloads such as might be encountered in heavy traction or severe duty industrial applications.

IMPULSE VOLTAGE STRENGTH

MAXI-CAST transformers have impulse levels equal to liquid-immersed transformers. The coils are very resistant to impulse voltage. Impulse withstand levels to 200kv are available because of careful design and special structure. The impulse voltage stress of the HV coil is evenly distributed throughout the winding due to a suitable winding arrangement.

SHORT CIRCUIT RESISTANT

The coil construction provides the highest mechanical withstand capability. The dynamic short circuit strength of a **MAXI-CAST** transformer is greatly superior to that of liquid-immersed or dry type transformers.

In the event of a maximum short circuit, **MAXI-CAST** transformers are not endangered mechanically, due to the dense glass fiber filling and the adhesion of epoxy resin to the conductors. In case of a short circuit, the conductors heat up much faster than the surrounding insulation.

Therefore only a strong glass fiber reinforced design, as found in cast resin transformers can prevent cracking of the coils and failure.

THERMAL SHOCK RESISTANCE

Tensile and bending strength of glass fiber reinforced epoxy resin (used in the **MAXI-CAST** design) is appreciably higher than that of quartz powder filled resin (used by mostly other manufacturers) has the disadvantage of becoming brittle and tending to crack when exposed to low temperature. Due to the complete combination of epoxy resin and glass fiber, even the worst temperature fluctuation will not induce the cracking of the coils in **MAXI-CAST** transformers.

FEATURES/CHARACTERISTICS

FIRE RESISTANT

MAXI-CAST transformers have an inherently safe characteristic of self fire-extinguishing and fire resistance. So there would be no fear of spread of fire even if a fire took place in near by equipment.

The transformers can be used indoors without fear of fire, and it is not necessary to provide additional measures for safety.



(a) (b) (c)

- a) Ignited for 2 minutes on the surface of cast coil with acetelene torch
- b) As the torch was removed from the surface of burning resin
- c) The flame extinguished by itself after 15 seconds

MAINTENANCE FREE

Maintenance is almost completely eliminated. No checking of liquid level and no yearly dielectric test for moisture absorption is required. Due to the smooth coil surfaces, heavy dirt and dust build up is eliminated even under the worst circumstances. The recommended routine maintenance is an occasional visual or Infra-Red thermal inspection.

ENVIRONMENTALLY SAFE

MAXI-CAST transformers will not emit oil or toxic gases into the atmosphere. Therefore, they do not pollute the environment and are recommended strongly as a replacement for askarel filled (PCB) transformers. PCB is poisonous, chemically aggressive and can discharge dangerous gases at elevated temperatures.

LOW NOISE

The encapsulation of the core in a special resin and the design of the clamping mechanism have provided an appreciable noise reduction. Noise is also reduced due to the sound suppressing effect of the elaborate core cutting and the coil support elastic structure.

COST SAVING

If the advantage of **MAXI-CAST** transformers are taken into consideration at the planning stage, the overall costs of a power supply system can often be considerably reduced. They are sufficiently compact for convenient installation in a building where space is generally limited and have much smaller power loss than oil-immersed and dry-type transformers. Total costs are lower even though cast resin transformers may be more expensive than other transformers. Cost savings add low maintenance and longer operating life in all conditions.

FEWER FAILURES

Stanadard Insurance Company studies have shown failure rates in cast coil transformers to be less than 5% that of standard dry type transformers in some applications

MAXI-CAST TRANSFORMER SECTION

- | | | |
|-----------------------|-------------------------|--------------------------|
| 1 Lifting Lugs | 10 Core Bolt Insulation | 18 HV Terminal |
| 2 LV Terminals | 11 Core Pressing Bolts | 19 HV Taps |
| 3 HV Coil | 12 Upper Frame | 20 Anti-Vibration Rubber |
| 4 LV Coil Termination | 13 Coil Clamp Adjustor | 21 Trolley Frame |
| 5 Core Bandage | 14 Tap Link | 22 Bi-directional Wheel |
| 6 LV Coil | 15 Resin Support Block | 23 HV Conductors |
| 7 Pulling Holes | 15A Resilient Pad | 24 Air Ducts for Cooling |
| 8 Lower Frame | 16 Core Leg | 25 LV Conductors |
| 9 Core Yoke | 17 Tie Bars | |

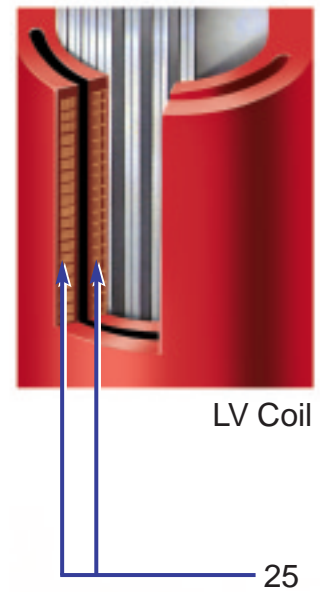
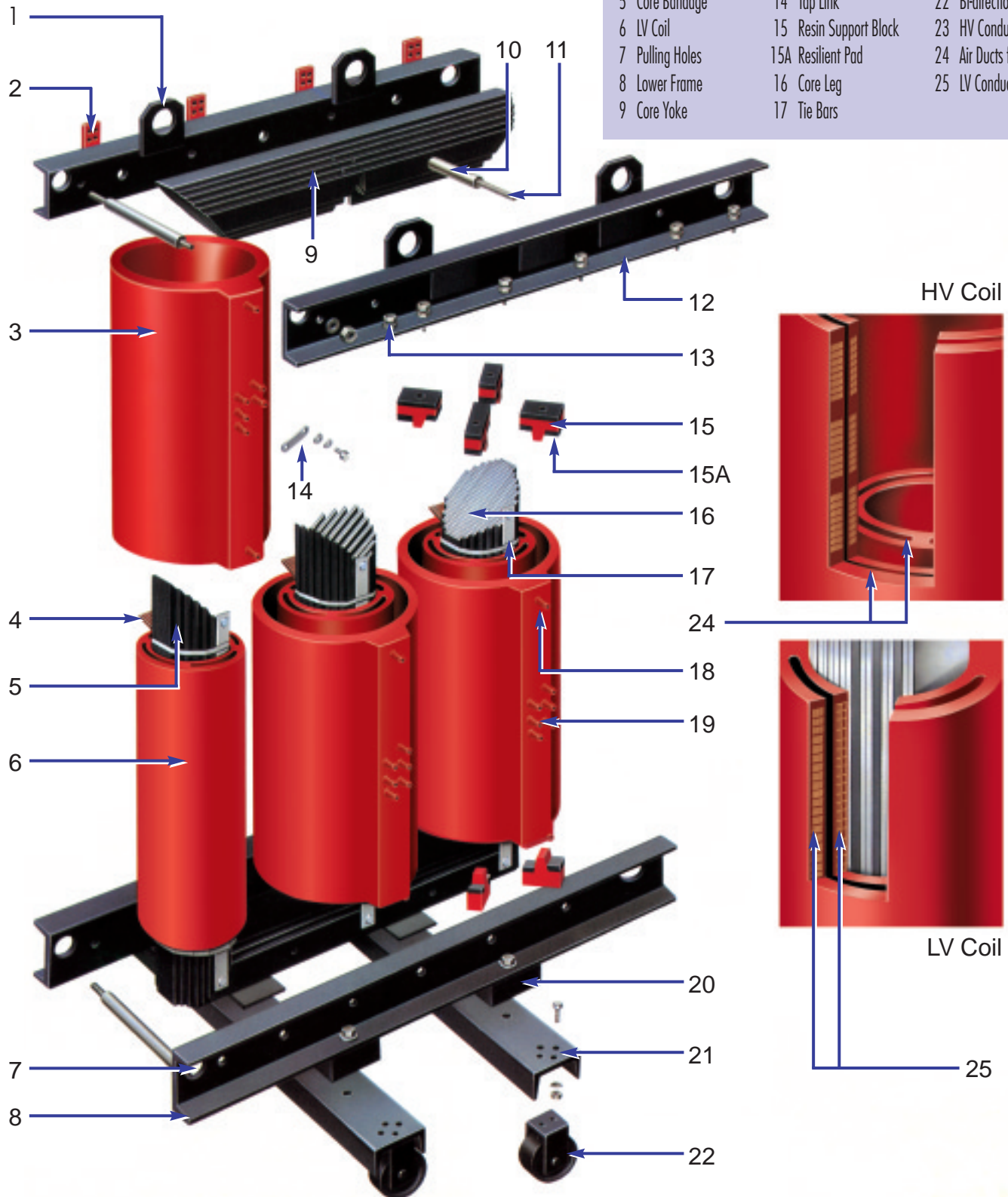

CONSTRUCTION

MAXI-CAST transformers prides itself in the ability to offer a wide variety of designs and configurations to satisfy most customer needs. Computers and CAD/CAM systems are used to quickly and accurately design and manufacture to meet specific customer requirements.

CORE AND FRAME

The core is made of the highest quality, cold-rolled, grain-oriented, high silicon content steel and accurately cut on the latest CNC machines.

Three legs of the core are arranged in a single plane and interconnected with a yoke. The legs are arranged circular structure multi-ply step-wise design, and are carefully interlaced with stepwise epoxy arranged yokes. The core is mitered at a 45° angle and carefully stacked to obtain very low losses, exciting current and noise. The core is insulated on both sides of each lamination and protected against corrosion by a resin coating and grounded in accordance with required standards.

The frame consists of upper and lower steel channels. It holds the core and coil together securely. The undercarriage is bolted to the bottom of the lower frame. Wheels enable the transformer to be moved either length-wise or side-wise.

Lifting lugs and grounding terminals are fitted to the upper and lower frame respectively. To protect against corrosion, all steel parts are coated with epoxy paint.

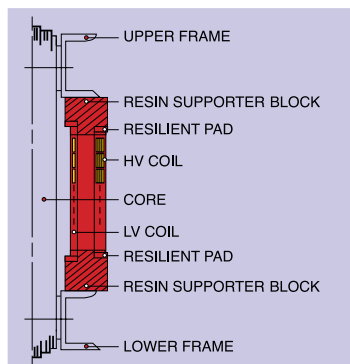

LOW VOLTAGE AND HIGH VOLTAGE WINDING

High grade insulated copper wire is used in all winding construction.

Turns are arranged in multiple sections and layers as dictated by design requirements. Cooling ducts are strategically placed within the windings to provide low thermal drop through thin sections of insulation, and provide smooth and even surfaces for effective convection or forced air cooling. The completed windings are placed in close tolerance with molds and cast under high vacuum conditions using a very low viscosity epoxy resin. The resin penetrates and saturates all portions of the windings. After the molds are filled with epoxy resin, they are moved into carefully programmed ovens where the epoxy resin is fully cured.

Finished coils contain smooth surfaces to enhance heat transfer to cooling air, and also prevent dirt or dust build-up. The complete saturation and penetration of the resin results in a winding free of partial discharge, well above operating voltage conditions. Glass cloth and fiberglass mat render outstanding mechanical strength properties as well to the finished product.

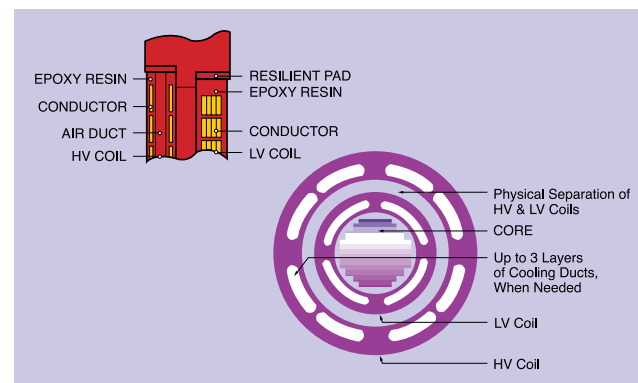

CONSTRUCTION

NO-VOLTAGE TAP CHANGER

MAXI-CAST transformers are provided with a re-connectable link tap changing device on the high voltage side of the transformer. This can be operated with the transformer de-energized only to change the ratio of the transformer.

The device is sturdy in construction, and the links are clearly identifiable as to the tap selected.

COOLING FANS

Forced cooling is a relatively simple method of increasing the capacity of cast resin transformers. This is especially advantageous for transformers which are highly loaded only for a few hours a day and then operated at a normal load for the rest of the time. Fans are mounted on both sides of the transformer base. Through the use of cooling fans, a capacity increase of 30 - 50% can be achieved with minimal efforts. It is also very effective at sites where the available space is limited and peak load conditions are only needed on a limited basis.

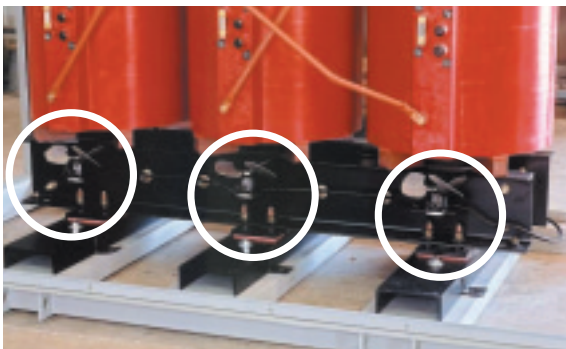

TEMPERATURE MONITORING UNIT

The temperature monitoring control system protects the coils against overheating due to increased ambient temperature or overload, and permits utilization of full transformer power at any required load cycle without hazard to the transformer.

This system consists of a protective relay and temperature sensors buried in the upper portion of the low voltage coils so that the direct temperature measurement of the coils can be made. When the temperature of the coils exceeds its set value, a control relay operates and closes the contacts. This can activate an alarm or start fans to cool the transformer.

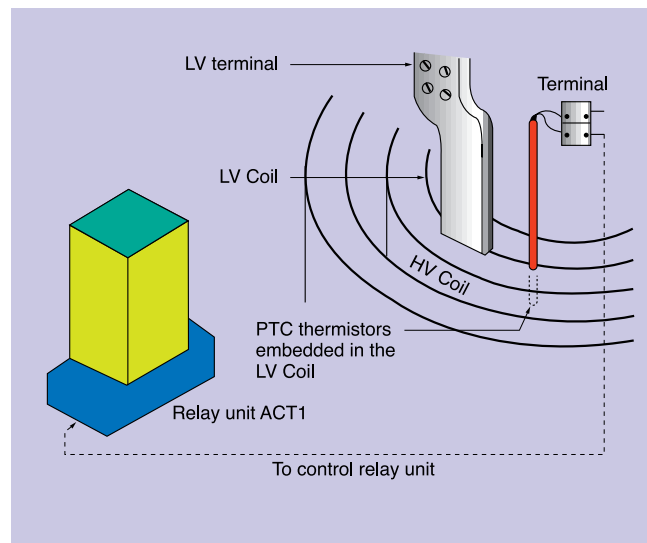

CONSTRUCTION

ENCLOSURE

MAXI-CAST transformers are normally supplied without an enclosure (Core and Coil only), Additional protection may be offered by an enclosure to protect against solid bodies and liquids.

*ENCLOSURE CBS1

(Nema 1 indoor)

This has protection against solid bodies greater than 12mm diameter and has louvered sheet steel or stainless steel walls.

The top panel is removable and the floor is open to allow cables to be inserted easily through the floor.

*ENCLOSURE CBS2

(Nema 3 outdoor)

This is similar to enclosure CBS1 but also has protection against rain and blowing water up to 60 degrees from the vertical.

Because this enclosure is used in outdoor applications it is equipped with a rain tight roof assembly and has hooded and filtered louvered walls.

ASSEMBLY

HV and LV coils are arranged coaxially and clamped rigidly. The support structure between the core and coils is resilient preventing the major part of vibrations and noise caused by magnetostriction.

The noise level is dampened to a level equivalent to that of oil-immersed transformers.

QUALITY ASSURANCE

Quality assurance begins with a tight control of incoming materials and is continuous throughout the various steps of the manufacturing process. Quality control is carried through the testing of each transformer and ends only when the transformer is installed and operating.

MAXI-CAST transformers are tested in accordance with ANSI and IEC standards prior to shipment, as noted below. Additionally, each high voltage coil is routinely tested before assembly as a means to verify the integrity of the epoxy impregnation.

Notes:

The **MAXI-CAST** factory has fully equipped laboratory facilities for testing cast epoxy resin transformers. Tests are performed as noted in the following table.

NO.	ITEMS	ROUTINE TEST	TYPE TEST	SPECIAL TEST
1	Measurement of winding insulation resistance	•		
2	Measurement of turns ratio	•		
3	Phase-relation test: Polarity, angular displacement and phase sequence	•		
4	No-load loss and exciting current	•		
5	Load loss and impedance voltage	•		
6	Applied potential dielectric test	•		
7	Induced voltage dielectric test	•		
8	Temperature rise test		•	
9	Impulse voltage test		•	
10	Measurement of sound level	•		
11	Measurement of partial discharges		•	
12	Short-circuit test			•
13	Heat cycle test			•

TECHNICAL DATA

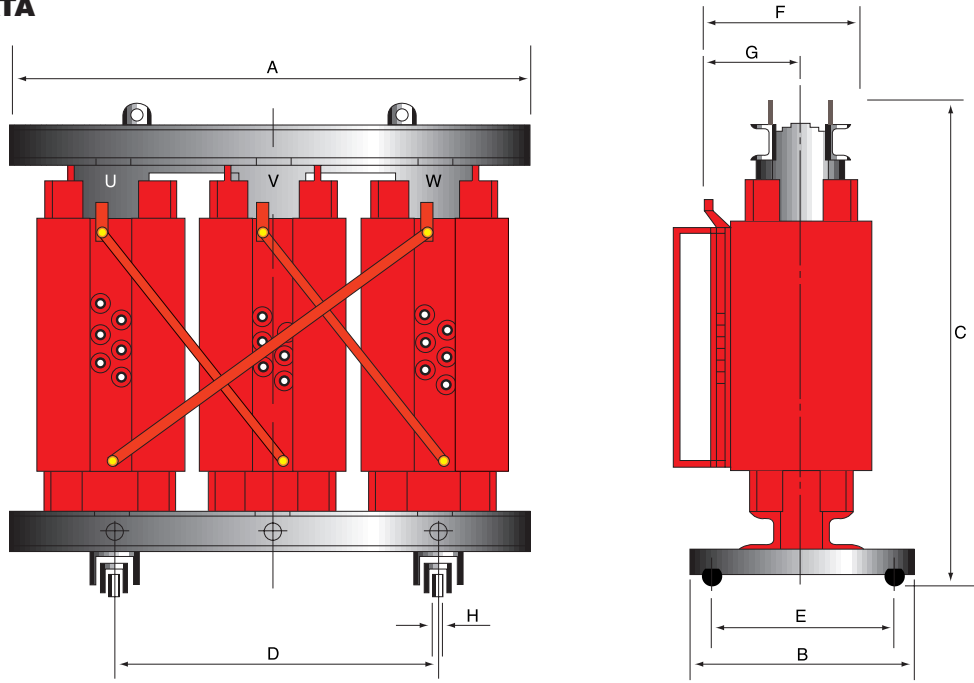

Temp. Rise 80/115/150C, 60Hz
Class 5KV, BIL HV; 75KV/LV; 30KV.
ANSI/IEEE C 57. 12. 01

Rated Power (KVA)	Type	Impedance Voltage (%)	No-Load Loss (W)	Load Loss (W) at 100°C	Dimension (inches)								Weight (lbs)
					A	B	C	D	E	F	G	H	
112.5	MC-1 12/5	5.75	450	2350	41.3	19.7	40.9	27.6	16.9	18.5	10.2	1.2	1210
150	MC-150/5	5.75	550	2900	41.3	19.7	47.2	27.6	16.9	18.5	10.2	1.2	1430
225	MC-225/5	5.75	700	3500	45.3	25.6	48.8	29.9	22.8	19.9	10.6	1.2	2120
300	MC-300/5	5.75	850	3800	45.3	25.6	53.1	29.9	22.8	19.9	10.6	1.2	2510
500	MC-500/5	5.75	1200	6300	53.5	25.6	58.3	34.6	22.8	22.2	11.8	1.2	3640
750*	MC-750/5	5.75	1800	7800	55.1	29.5	67.7	36.6	24.1	23.8	12.4	1.9	4890
1000*	MC-1000/5	5.75	2300	9000	59.1	29.5	72.8	38.6	24.1	24.4	13.0	1.9	6060
1500*	MC-1500/5	5.75	3100	13500	66.9	37.4	82.7	44.5	29.9	27.2	14.4	1.9	7300
2000*	MC-2000/5	5.75	3600	16600	70.9	37.4	88.6	46.9	29.9	27.8	14.6	1.9	9900
2500*	MC-2500/5	5.75	4600	19000	78.7	40.2	95.3	46.9	29.9	27.8	14.6	1.9	11000

* Indicates stock units ready to ship.

NOTE: These are maximum dimensions. Actual production transformer may be slightly smaller.

TECHNICAL DATA

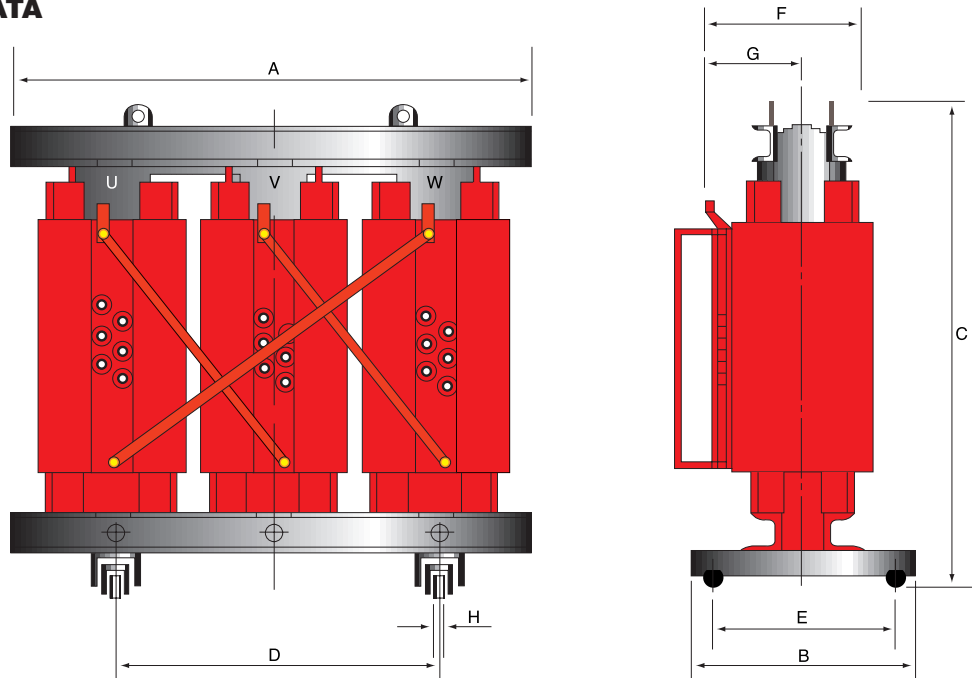

Temp. Rise 80/115/150C, 60Hz
 Class 15KV, BIL HV; 110KV/LV; 30KV.
 ANSI/IEEE C 57. 12. 01

Rated Power (KVA)	Type	Impedance Voltage (%)	No-Load Loss (W)	Load Loss (W) at 100°C	Dimension (inches)								Weight (lbs)
					A	B	C	D	E	F	G	H	
112.5	MC-1 12/15	5.75	520	2700	44.1	25.6	45.3	30.0	22.8	20.0	10.4	1.2	1370
150	MC-150/15	5.75	650	3200	41.1	25.6	51.6	30.0	22.8	20.0	10.4	1.2	1590
225	MC-225/15	5.75	850	3700	51.2	29.5	54.7	33.5	24.1	23.2	11.2	1.9	2360
300	MC-300/15	5.75	1000	4300	51.2	29.5	61.4	33.5	24.1	23.2	11.2	1.9	2820
500	MC-500/15	5.75	1550	7100	59.1	29.5	68.9	39.4	24.1	27.6	12.8	1.9	4270
750*	MC-750/15	5.75	2100	8600	63.0	37.4	74.4	41.7	30.0	27.8	13.2	1.9	5580
1000*	MC-1000/15	5.75	2750	9000	68.9	37.4	76.8	45.7	30.0	28.1	14.4	1.9	7120
1500*	MC-1500/15	5.75	3500	12000	70.0	40.2	82.7	46.9	34.3	29.9	14.8	1.9	8300
2000*	MC-2000/15	5.75	4600	16600	78.7	40.2	91.7	51.6	34.3	31.7	15.9	1.9	11660
2500*	MC-2500/15	5.75	5200	19000	83.5	40.2	98.4	51.6	34.3	31.7	15.9	1.9	13400

* Indicates stock units ready to ship.

NOTE: These are maximum dimensions. Actual production transformer may be slightly smaller.

SPECIFICATION

SPECIFICATION DATA

MAXI-CAST transformers are normally available with specification as follows:

Rated Voltage

- HV coil: Up to 36KV
- LV coil: 0.48-4.16 KV
- * **MAXI-CAST** transformers with multiple high voltage connections can also be supplied.

Tap Range

- Standard: $\pm 2.5\%$, $\pm 5\%$
- * Other ratings are available by arrangement.

Power Capacity

- Single phase. 20 - 2,000 KVA
- Three phase: 50 - 10,000 KVA
- Frequency: 50Hz, 60Hz
- Typical % impedance voltage: 4-8%

Connections

- HV coil: Delta
- LV coil: Wye with neutral point
- * Other connections are available to meet requirements.

Temperature ratings (according to ANSI C-57)

- HV coil: Class F
- LV coil: Class F
- Max. ambient temperature: 40° C
- Temperature rise limitation: 150° C

Tolerance (according to ANSI C-57)

- Total losses: +10%
- Component losses: +15%
(No-load and load losses)
- No-load current: +30%
- Impedance voltage: $\pm 10\%$
(at rated current)
- Voltage ratio: $\pm 0.5\%$ or 1/10 of measured impedance voltage at rated current.

STANDARDS

MAXI-CAST transformers conform to the requirements of ANSI/IEEE C57-12.01 (1979) standards. However they can also meet the requirements of the following standards, upon request:

- ANS IEC726 (1982)
General requirements for dry-type distribution and power transformers
- BS-171 (1978)
Power transformers
- CSA standard C9-M (1981)
Dry-type transformer
- AS2374 (1982)
Power transformer
- VDE 0532 (1982)
* Transformers for rectifier applications and other special purposes can be supplied according to the client's specification (Rapid Transit System, Air and Iron Core Reactors, Precipitator Transformers etc.)

ACCESSORIES

NORMALLY PROVIDED ACCESSORIES

- Terminal screws and links for HV taps
- Nameplate
- Ground wire clamping screw
- Protective cap for HV taps
- Lifting lugs
- Danger labels
- Installation manual

OPTIONAL ACCESSORIES

- PTC thermistor & relay unit
- Wheels
- Dial-type thermometer
- Anti-vibration pads
- Enclosure
- Anchor bolts

SPECIAL ACCESSORIES

- Cooling fans and control relay

GROUP CBS, INC.

WE PROVIDE
QUALITY
MAINTENANCE,
REPAIR AND
SUPPLY SERVICES
WORLDWIDE

www.electrical911.com

www.groupcbs.com

Circuit Breaker Sales Co., Inc.

World's largest inventory of low and medium voltage circuit breakers. Millions of parts in stock. Complete service, remanufacture and upgrade capabilities including building new or matching existing switchgear lineup from 480V to 34.5kV.

Tel: 800-232-5809 www.circuitbreakersales.com

Arc Technology, Inc.

Electrical contact retipping and replacement for oil switches, air switches, tap changers, regulators, circuit breakers, motor starters and reclosers.

Tel: 253-735-0485 www.arc-technology.com

CBS Power Products, Inc.

New alternative utility and industrial power products. Transformers, vacuum circuit breakers and other power apparatus.

Tel: 972-250-2500 www.cbspowerproducts.com

Northwest Circuit Breakers, Inc.

Serving the Pacific Northwest with shop or field service, repair, upgrade or replacement of power system apparatus.

Tel: 253-735-0192 www.nwcircuitbreakers.com

Solid State Exchange & Repair, Inc.

Service and support for all brands and types of solid state power electronics including circuit breaker trip devices, rating plugs, protective relays and more.

Tel: 940-243-3731 www.solidstaterepair.com

Circuit Breaker Sales & Repair, Inc.

Servicing the Gulf Coast with shop or field service, repair, upgrade or replacement of power system apparatus.

Tel: 713-921-4545 www.cbsalesandrepair.com

Transformer Sales Co.

Dry, cast coil and liquid filled transformers up to 34.5kV.

Tel: 940-665-4484 www.transformersales.com

Instel Power Services, Inc.

Serving the Southeast with onsite testing, maintenance and repair services. Full NETA shop specializing in onsite maintenance and power quality monitoring.

Tel: 864-288-0991 www.instelpower.com

Sentinel Power Services, Inc.

Serving the Central U.S. with onsite testing, maintenance and repair services for low and medium voltage substations, switchgear, transformers, circuit breakers and protective relays.

Tel: 800-831-9550 www.sentinelpowerservices.com

Astro Controls, Inc.

Sales and service for all types of industrial molded case circuit breakers and motor controls.

Tel: 800-289-2757 www.astrocontrols.com



LG Industrial Systems Co., Ltd.

<http://www.lgindustrialsystems.com>

G R O U P
CBS INC

P.O. Box 1557
Gainesville, Texas 76240

Tel: 940-665-6026

Fax: 940-665-4681

E-mail: info@groupcbs.com



P.O. Box 703766

Dallas, Texas 75370

Tel: 972-250-2500

Fax: 972-250-2501

E-mail: info@cbspowerproducts.com